

NAME _____ INDEX NUMBER _____

SCHOOL _____ DATE _____

SALTS

1. 1989 Q 34b,c

- (a) Explain how sodium carbonate can be used to soften hard water.
(Use ionic equations where necessary). (3 marks)

.....
.....
.....
.....
.....
.....

- (b) Give one other commercial use of sodium carbonate, besides softening of hard water. (1 mark)

.....

2. 1989 PP1A QUESTION 7

What would be observed when aqueous sodium hydroxide is added to aqueous lead (II) nitrate?

.....
.....
.....

3. 1989 PP1A QUESTION 18

P, Q and R are solutions of lead nitrate, sodium chloride and magnesium Sulphate (not in that order) Use the following information to identify P and Q

- (i) When drops of barium chloride solutions are added to separate portions of P, Q and R, a white P is formed
- (ii) When dilute hydrochloric acid is added to separate portions of Q and R, a white precipitate is observed in R but Q remains clear. (1 mark)

.....
.....

4. 1991 PP1A QUESTION 27

The following is a procedure that was used to obtain the solubility of a salt Q in water at 25°C. Study it and answer the questions that follow.

Salt Q was dissolved in warm distilled water until no more could dissolve. The mixture was then cooled to 25°C and allowed to settle.

A dry evaporating dish and dry watch glass were weighted. Some of the solution was decanted into the dish, covered with the watch glass, and then weighed.

The solution was evaporated to dryness over a small flame. This residue, the dish and the watch glass were weighted. The residue was then heated repeatedly until a constant mass was obtained. The results below were obtained.

Mass of dish + Watch glass = 50.60g

Mass of solution + dish + watch glass = 80.6g

Mass of residue + dish + watch glass = 62.60g

(i) What is the purpose of a watch glass in such an experiment? (1 Mark)

.....
.....

(ii) Why should the heating be continued until a constant mass is obtained (1 Mark)

.....
.....

(iii) Calculate the mass of the solution (1 Mark)

.....
.....
.....

(iv) Calculate the mass of the residue (1 Mark)

.....
.....
.....

(v) Calculate the mass of the water

(1 Mark)

(vi) Calculate the solubility of salt Q in g per 100g of water at 25°C (2 Marks)

5. **1992 PP1A QUESTION 15**

Explain how you would distinguish between a carbonate and a sulphite using a dilute acid and red litmus paper.

6. **1994 PP1A QUESTION 30**

Study the solubility curves below and answer the questions that follow.

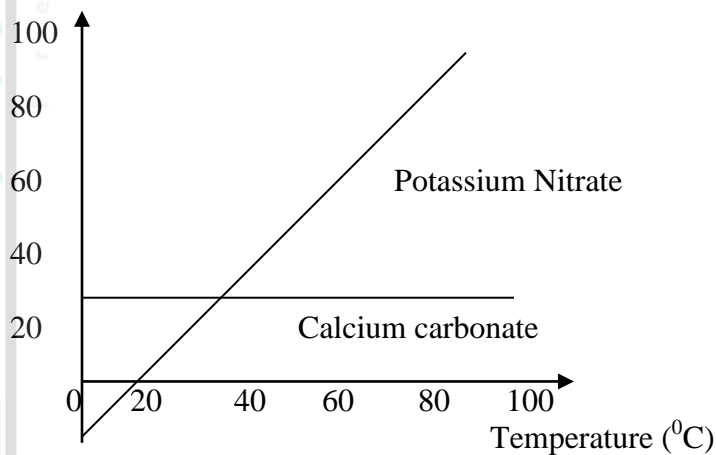

(a) At what temperature would equal amounts of potassium nitrate and calcium ethanoate dissolve in 100g of water? (1 Mark)

(b) Explain how you would prepare a saturated solution containing 80g of potassium nitrate in distilled water. (1 Mark)

.....
.....
.....
.....

(c) A student added 30g of Calcium ethanoate to 100g of boiling water and noticed that not all of it dissolved. Explain what would happen if the student cools the mixture with stirring up to a temperature of 10°C (1 Mark)

.....
.....
.....

7. 1995 PP1A QUESTION 21

The table below shows how solubility of some substances in water varies with temperature.

Substance	Change of solubility with temperature (g/100cm ³ of water)			
	0°C	20°C	40°C	60°C
W	0.334	0.16	0.097	0.0058
X	27.60	34.0	40.0	45.5
Y	35.70	36.0	36.6	37.3

Which of the above substances is likely to be a gas? Explain. (2 Marks)

.....
.....
.....

8. 1995 PP1A QUESTION 25

Describe how the following reagents can be used to prepare lead Sulphate, Solid potassium sulphate, solid lead carbonate, dilute nitric acid, and distilled water (2 marks)

.....
.....
.....
.....

9. 1995 PP1B Q 5

The flow charts below show an analysis of a mixture R that contains two salts. Study the analysis and answer the questions that follow.

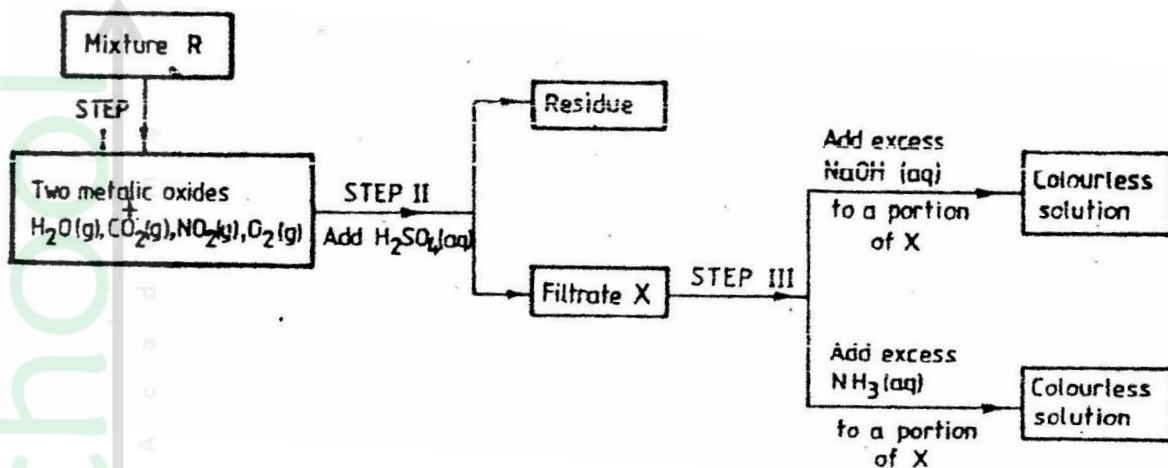

(a) (i) What condition is necessary for the process in step I to take place? (1 mark)

.....

(ii) Draw a labelled diagram for the set-up that could be used to separate the mixture formed in step II (2 marks)

(iii) Write ionic equation for the reaction between the cation in filtrate X and aqueous ammonia. (1 mark)

.....

(iv) What observation would indicate the presence of $\text{NO}_2(\text{g})$ in step I

.....

(v) State how water vapour, in step I could be identified. (1 mark)

.....

.....

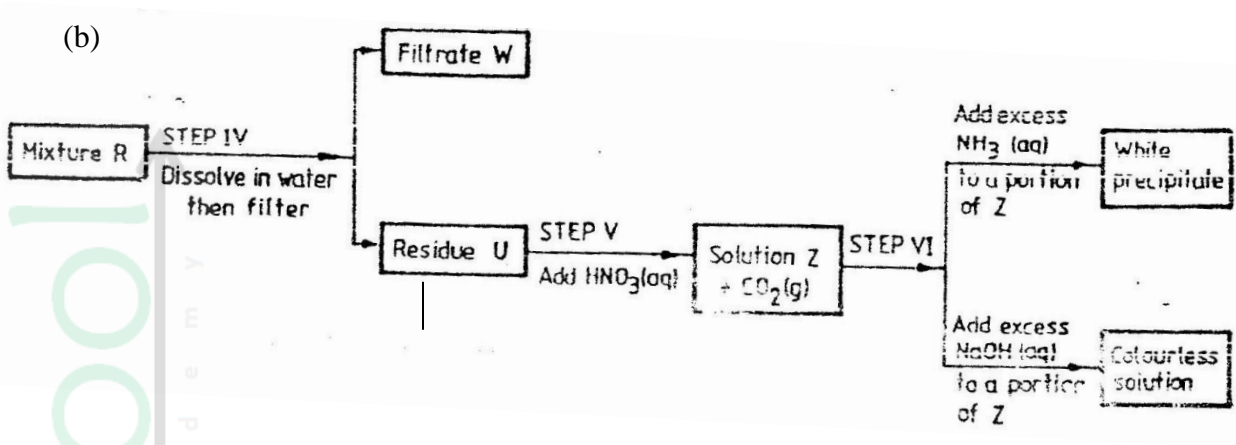

(i) What conclusion can be drawn from step iv only? Explain? (2 marks)

.....

.....

.....

.....

(ii) Write the formula of an anion present in the residue U. Explain (2 marks)

.....

(iii) Suggest the identity of the cation present in solution z. (1 mark)

.....

(c) Name the two salts present in the mixture R. (2 marks)

.....

.....

10. 1996 PP1B Q 6

a) Give the name of each of the processes described below which takes place when salts are exposed to air for some time.

i) Anhydrous copper sulphate becomes wet (1 mark)

.....

ii) Magnesium chloride forms an aqueous solution (1 mark)

.....

iii) Fresh crystals of sodium carbonate, $\text{Na}_2\text{CO}_3 \cdot 10\text{H}_2\text{O}$ (1 mark)

.....

- b) Write the formula of the complex ion formed in each of the reactions described below.
- (i) Zinc metal dissolves in hot alkaline solution (1 mark)

.....

- (ii) Copper hydroxide dissolves in excess ammonia solution. (1 mark)

.....

- (c) A hydrated salt has the following composition by mass. Iron 20.2% Oxygen 23.0%, sulphur 11.5%, water 45.3 %. Its relative formula mass is 278.

- (i) Determine the formula of the hydrated salt.. (3 marks)
(Fe=56, S=32; O = 16, H =1)

.....
.....
.....
.....

- (ii) 6.95gm of the hydrates salt were dissolved in distilled water and the total volume made to 250 cm³ of solution. Calculate the concentration of the salt. solution in moles per litre

.....
.....
.....
.....

11. 1998 PPIA QUESTION 2

Study the information in the table and answer the question below the table

Substance	Solubility g/100g water
A	1.26×10^{-2}
B	1.09×10^{-2}

Describe how a solid sample of substance A could be obtained from a solid mixture of A and B.

(2 marks).

.....
.....
.....
.....

12. 1998 PP1A QUESTION 19

Describe how a solid sample of lead (ii) chloride can be prepared using the following reagents. Dilute nitric acid, and lead carbonate (2 marks)

.....
.....
.....
.....

13. 1999 PP1A Q 2

Study the flow chart below and answer the questions that follow

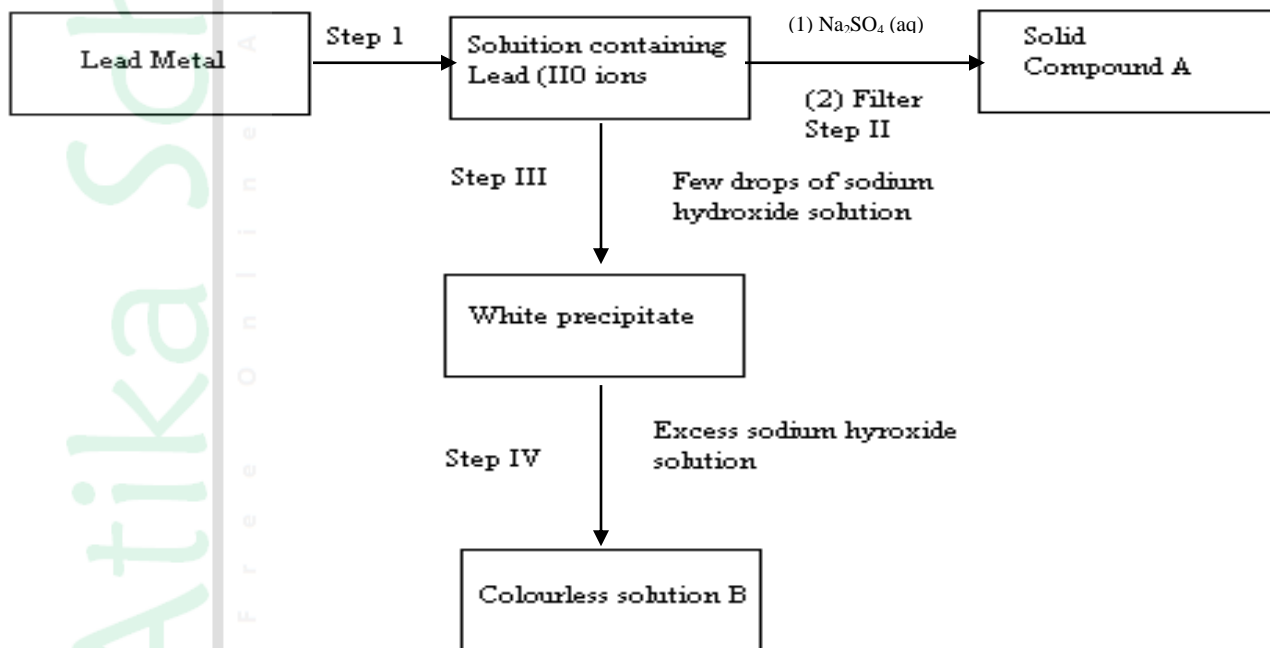

(a) Name:

(i) The reagent used in step I

(ii) Compound A

(b) Write an ionic equation for the reaction in step IV

.....
.....
.....

15. 1999 PP1B Q 4

a) The flow chart below shows a sequence of reactions starting with Iron. Study and answer the questions that follow.

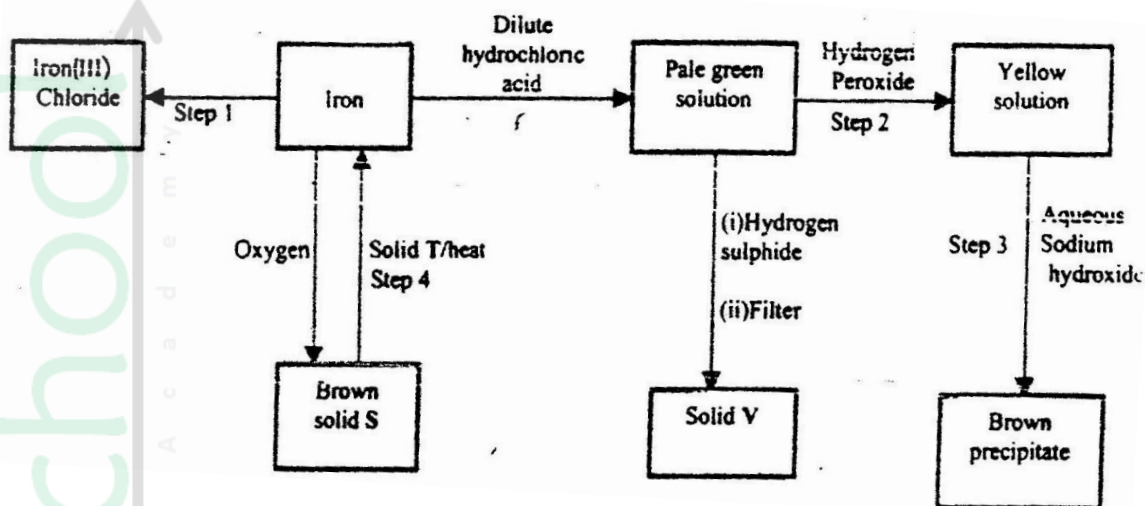

i) Name the reagent and state the condition for the reaction in step.

ii) Give the names of the following

i) Solid S

ii) Solid V

iii) Solid T

iii) Give reasons for the colour change in step 2

iv) Write an ionic equation for the reaction which takes place in step 3.

v) Name one other substance that could be used instead of sodium hydroxide in step III.

b) In an experiment 3.36g of iron fillings were added to excess aqueous copper (II) sulphate. Calculate the mass of copper that was deposited. Cu = 63.5, Fe = 56.0

16. 1999 PP1A QUESTION 3

State and explain the observations that would be made when a few drops of concentrated Sulphuric acid are added to a small sample of hydrated copper (II) sulphate. (2 Marks)

.....

.....

.....

.....

17. 1999 PP1A QUESTION 8

The table below shows the solubility of a salt at various temperatures.

Temperature (0C)	Solubility g/100g water
0	36
40	30
80	25
110	20

What would happen if a sample of a saturated solution of the salt at 40⁰C is heated to 80⁰C? (2 Marks)

.....

.....

.....

.....

18. 2000 Q 8 PP1

Study the solubility curves below and answer the questions that follow

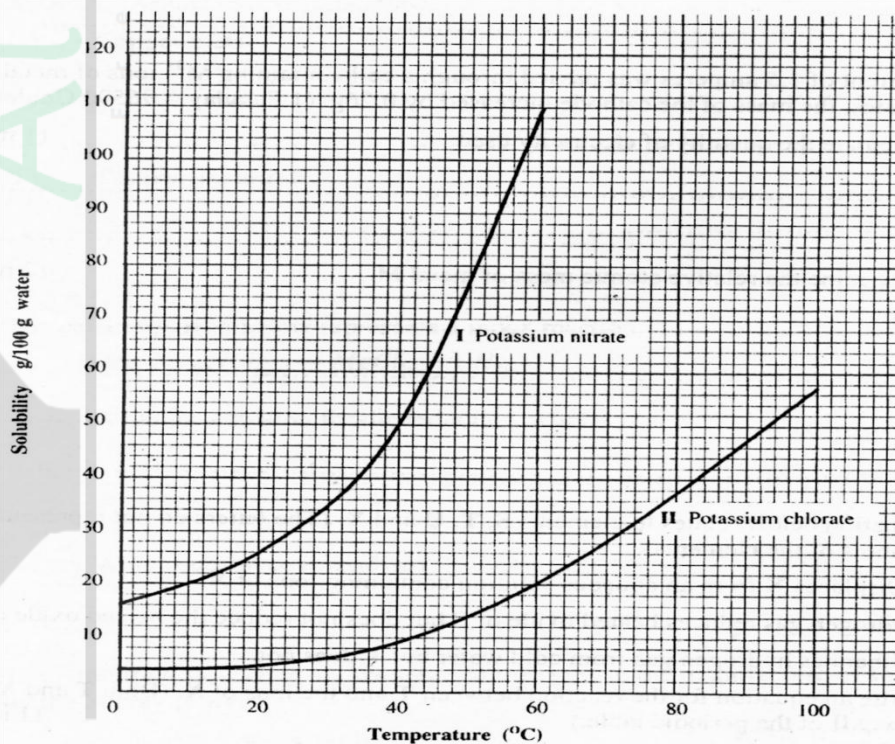

What happens when a solution containing 40gm of potassium chlorate and 40gm of potassium nitrate in 100gm of water at 90⁰C is cooled to 40⁰C? Explain

.....
.....
.....
.....

19. 2001 Q 6c P2

c) Neutralization is one of the methods of preparing salts.

i) What is meant by neutralization?

.....
.....

ii) Describe how you would prepare crystals of sodium nitrate starting with 200cm³ of 2M sodium hydroxide.

.....
.....
.....
.....

iii) Write an equation for the reaction that takes place when a solid sample of sodium nitrate is heated.

.....

20. 2003 Q 1c P2

Starting with aqueous magnesium sulphate, describe how you would obtain a sample of magnesium oxide. (3 marks)

.....
.....
.....
.....
.....

21. 2004 Q 2b P2

(b) The scheme below shows some reactions starting with calcium oxide. Study it and answer the questions that follow.

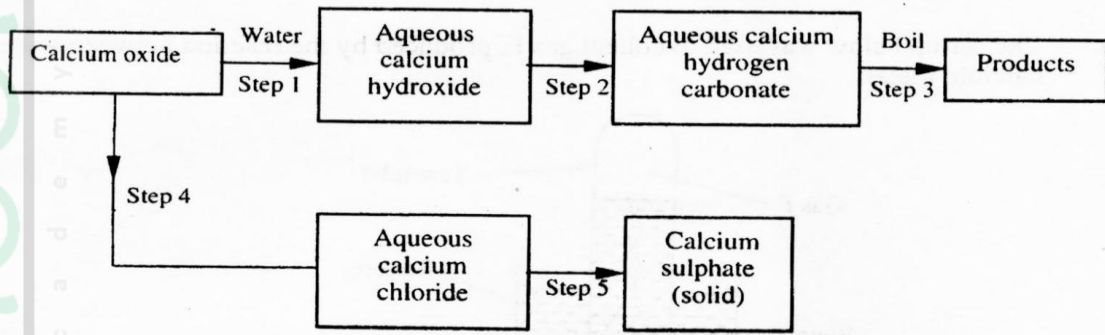

(i) Name the reagents used in steps 2 and 4 (2 marks)

.....

(ii) Write an equation for the reaction in step 3. (1 mark)

.....

(ii) Describe how a solid sample of anhydrous calcium sulphate is obtained in Step 5

.....

22. 2005 Q2a P2

(a) Name one raw material which sodium hydroxide is manufactured (1 mark)

.....

23. 2005 Q 1

State one use of sodium hydrogen carbonate. (1 mark)

.....

24. 2006 Q 27

Study the flow chart below and answer the questions that follow.

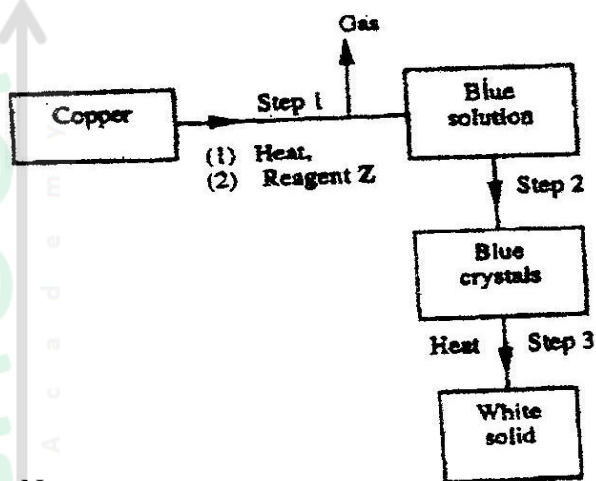

a) Name reagent z.

.....

b) Describe the process which takes place in step 2. (1 mark)

.....

c) Identify the white solid. (1 mark)

.....

25. 2007 Q 6

In an experiment, a few drops of concentrated nitric acid were added to aqueous iron(II) sulphate in a test – tube. Excess sodium hydroxide solution was then added to the mixture.

a) State the observations that were made when:

i) Concentrated nitric acid was added to aqueous iron (II) sulphate (1 mark)

.....

ii) Excess sodium hydroxide was added to the mixture. (1 mark)

.....

b) Write an ionic equation for the reaction which occurred in (a) (ii) above. (1 mark)

26. 2007 Q 9

Study the flow chart below and answer the question that follows.

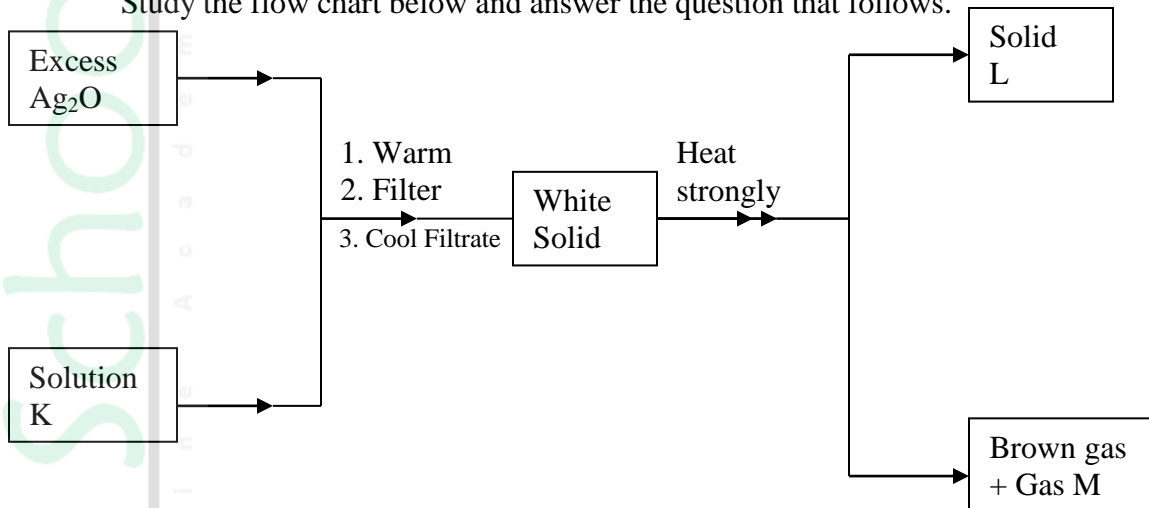

Identify:

- a) Solution K
- b) Solid L
- c) Gas M

(3 marks)

27. 2007 Q 13

a) Name the process that takes place when:

- (i) Crystals of zinc nitrate change into solution when exposed to air (1 mark)

28. 2007 Q 18

Starting with sodium metal, describe how a sample of crystals of sodium hydrogen carbonate may be prepared. (3 marks)

.....

.....

.....

.....

29. 2007 Q 3 P2

The flow chart below shows a sequence of chemical reactions starting with copper study it and answer the questions that follow.

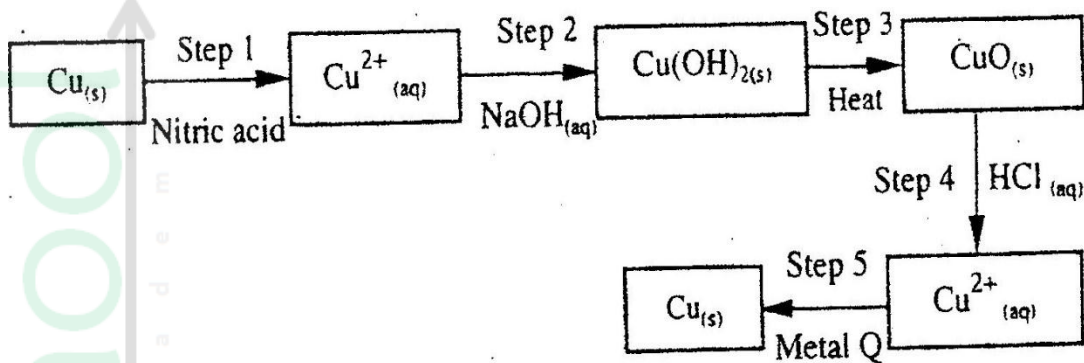

- (a) In step 1, excess 3M nitric acid was added to 0.5g of copper powder
 (i) State two observations which were made when the reactions was in progress (2 marks)

.....

.....

- (ii) Explain why dilute hydrochloric acid cannot be used in step 1 (1 mark)

.....

.....

- (iii) I Write the equation for the reaction that took place in step 1 (1 mark)

.....

.....

- II Calculate the volume of 3M nitric that was needed to react completely with 0.5g of copper powder. (Cu = 63.5) (3 marks)

.....

.....

.....

.....

.....

.....

- (b) Give the names of the types of reactions that took place in steps 4 and 5 (1 mark)

.....

.....

.....

- c) Apart from the good conductivity of electricity, state two other properties that make it possible for copper to be extensively used in the electrical industry. (2 marks)

.....

30. 2007 Q 6b P2

- (b) The table below shows the solubility of ammonium phosphate in water at different temperatures.

Temperature (C ⁰)	Solubility of ammonium phosphate in g/100g water
10	63.0
20	69.0
30	75.0
40	82.0
50	89.0
60	97.0

- (i) On the grid provided, draw the solubility curve of ammonium phosphate (Temperature on x – axis) (3 marks)
- (ii) Using the graph, determine the solubility of ammonium phosphate at 25⁰C (1 mark)

.....

- (iii) 100g of a saturated solution of ammonium phosphate was prepared at 25⁰C
 I what is meant by a saturated solution? (1 mark)

.....

- II Calculate the mass of ammonium phosphate which was used to prepare the saturated solution (2 marks)

.....

31. 2008 Q 15

The table below gives the solubilities of substances J, K and L at different temperatures

Substance	Solubility in grammes per 100 g water at			
	0°C	20°C	40°C	60°C
J	0.334	0.16	0.097	0.0058
K	27.60	34.0	40.0	45.5
L	35.70	36.0	40.0	37.3

Select the substance which, when dissolved in water, heat is given out. Give a reason

(2 marks)

.....

.....

32. 2008 Q 16

Starting with copper metal, describe how a sample of crystals of copper (II) chloride may be prepared in the laboratory. (3 marks)

.....

.....

.....

.....

33. 2008 Q 17

A compound whose general formula is $M(OH)_3$ reacts as shown by the equation below.

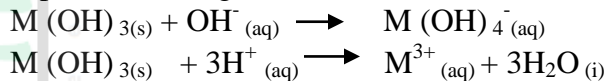

(a) What name is given to compounds which behave like $M(OH)_3$ in the two reactions

(1 mark)

.....

.....

(b) Name two elements whose hydroxides behave like that of M

(2 marks)

.....

.....

34. 2009 Q 2

Hardness of water may be removed by either boiling or addition of chemicals.

a) Write an equation to show how boiling removes hardness of water.

(1 mark)

.....

b) Name two chemicals that are used to remove hardness of water

(2 marks)

35. 2009 Q 11

Starting with 50 cm³ of 2.8M sodium hydroxide, describe how a sample of pure sodium sulphate crystals can be prepared. (3 marks)

36. 2009 Q 18

Bottle of sodium carbonate, sodium chloride and sugar have lost their labels. A student prepares and tests an aqueous solution of a sample from each bottle. The results obtained are as shown in the table below.

Bottle	pH	Electrical conductivity	Correct label
1	7	conducts	
2	7	Does not conduct	
3	10	conducts	

Complete the table by filling the correct label for each bottle.

37. 2009 Q 23

Use the flow chart below to answer the questions that follow.

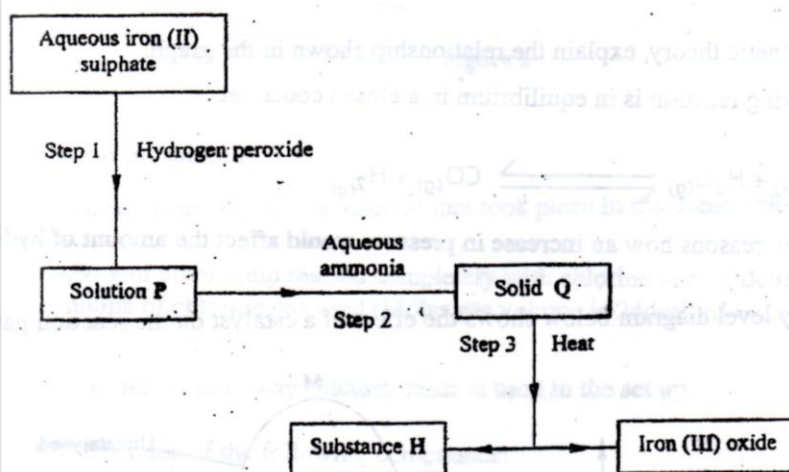

(a) What observation would be made in step I (1 mark)

.....
.....

(b) Name another substance that could be used in step 2 (1 mark)

.....

(c) Give the name of substance H.

38. 2009 Q 25

For each of the following reactions, state the observation and write the formula of the compound responsible for the observation

(a) Bromide water is added to aqueous potassium iodine (1 ½ mark)

.....
.....
.....

(b) Excess aqueous ammonia is added to copper (II) hydroxide (precipitate)

.....
.....
.....

39. 2010 Q 5

Hydrate cobalt(II) chloride exists as pink crystals and anhydrous cobalt(II) chloride is a blue powder. Describe a laboratory experiment that can be used to show that the action of heat on hydrated cobalt(II) chloride is a reversible reaction. (3 marks)

.....
.....
.....
.....

40. 2010 Q 24

Describe how a solid sample of the double salt, ammonium iron(II) sulphate, can be prepared using the following reagents; Aqueous ammonia, sulphuric(VI) acid and iron metal. (3 marks)

.....
.....
.....

41. 2011 Q 3

A mixture contains ammonium chloride, copper (II) oxide and sodium chloride.
Describe how each of the substances can be obtained from the mixture

(3 marks)

42. 2011 Q 13

Distinguish between the terms deliquescent and efflorescent as used in chemistry.

(2 marks)

43. 2011 Q 30

A sample of river water is suspected to contain zinc ions. Describe how the presence of zinc ions and sulphate ions can be established.

(3 marks)

44. 2011 Q 4 P2

a) When excess calcium metal was added to 50 cm³ of 2 M aqueous copper (II) nitrate in a beaker, a brown solid and bubbles of gas were observed.

i) Write two equations for the reactions which occurred in the beaker. (2 marks)

ii) Explain why it is not advisable to use sodium metal for this reaction. (2 marks)

- b) Calculate the mass of calcium metal which reacted with copper (II) nitrate solution.
(relative atomic mass of Ca=40) (2 marks)

- c) The resulting mixture in (a) above was filtered and aqueous sodium hydroxide added to the filtrate drop wise until in excess. What observations were made? (1 mark)

- d) i) Starting with calcium oxide, describe how a sample of calcium carbonate can be prepared. (3 marks)

- ii) Name one use of calcium carbonate. (1 mark)

45. 2012 Q6 P1

Study the information in the table below and answer the questions that follow:

Salt	Solubility (g/100g water)	
	At 40°C	At 60°C
CuSO ₄	28	38
Pb(NO ₃) ₂	79	98

A mixture containing 35g of CuSO₄ and 78g of Pb(NO₃)₂ in 100g of water at 60°C was cooled to 40°C.

- (a) Which salt crystallised out? Give a reason (2 marks)

- (b) Calculate the mass of the salt that crystallised out (1 mark)

46. 2012 Q16 P1

Use the following information on substances S, T, V and hydrogen to answer the questions that follow:

- (i) T displaces V from a solution containing V ions
- (ii) Hydrogen reacts with the heated oxide of S but has no effects on heated oxide of V.

(a) Arrange substances S, T, V and hydrogen in the order of increasing reactivity. (2 marks)

.....

.....

(b) If T and V are divalent metals, write an ionic equation for the reaction in (i) above. (2 marks)

.....

.....

47. 2012 Q6 P2

The flow chart below shows a sequence of reaction involving a mixture of two salts, mixture M. study it and answer the questions that follow.

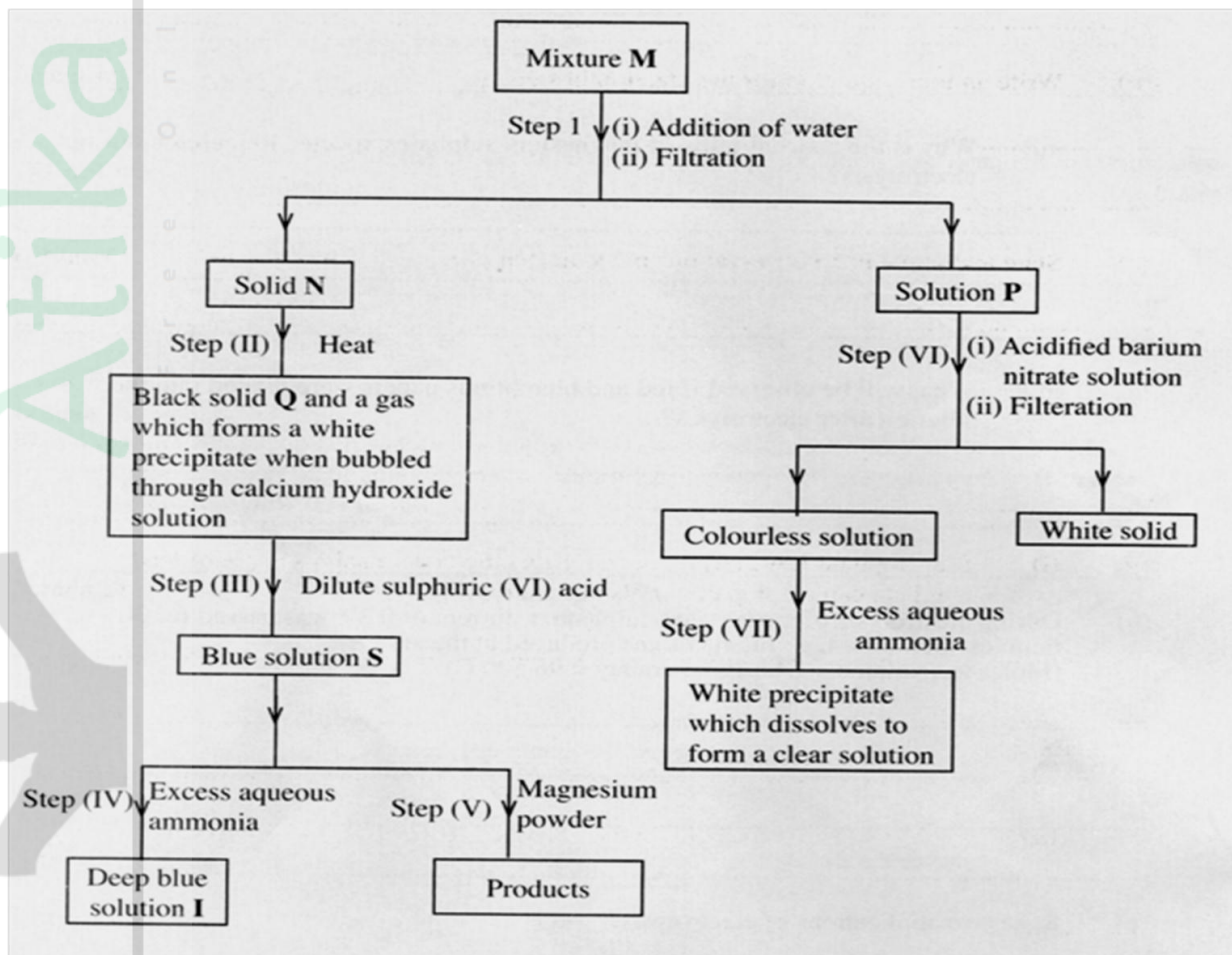

(a) Write the formula of the following (1 mark)

(i) Anion in solid **Q** (1 mark)

(ii) The two salts present in mixture **M** (2 marks)

(b) Write an ionic equation for the reaction in step (VI) (1 mark)

(c) State and explain the observations made in step (V) (3 marks)

(d) (i) Starting with Lead (II) oxide, describe how a pure solid sample of lead sulphate can be prepared in the laboratory (2 marks)

(ii) How can one determine whether the lead sulphate prepared is pure (2 marks)